

JET

JOSS-S

Oscillating Spindle Sander

Original:

GB
Operating Instructions

Translations:

D
Gebrauchsanleitung

F
Mode d'emploi



JPW (Tool) AG

Tämplerlistrasse 5
CH-8117 Fällanden
Switzerland

Phone +41 44 806 47 48

Fax +41 44 806 47 58

www.jettools.com



**CE-Conformity Declaration
CE-Konformitätserklärung
Déclaration de Conformité CE**

Product / Produkt / Produit:
Oscillating Spindle Sander
Oszillierende Spindelschleifmaschine
Ponceuse à Broche Oscillante

JOSS-S

Brand / Marke / Marque:

JET

Manufacturer / Hersteller / Fabricant:
JPW (Tool) AG, Tämperlistrasse 5, CH-8117 Fällanden
Schweiz / Suisse / Switzerland

We hereby declare that this product complies with the regulations
Wir erklären hiermit, dass dieses Produkt der folgenden Richtlinie entspricht
Par la présente, nous déclarons que ce produit correspond aux directives suivantes

2006/42/EC
Machinery Directive
Maschinenrichtlinie
Directive Machines

designed in consideration of the standards
und entsprechend folgender zusätzlicher Normen entwickelt wurde
et été développé dans le respect des normes complémentaires suivantes

EN ISO 12100:2010
EN 60204-1:2006+A1:2009

Responsible for the Documentation / Dokumentations-Verantwortung / Responsabilité de Documentation
Head Product-Mgmt. / Leiter Produkt-Mgmt. / Resp. Gestion des Produits
JPW (Tool) AG



2018-03-01 Jan Dätwyler, General Manager
JPW (Tool) AG, Tämperlistrasse 5, CH-8117 Fällanden
Schweiz / Suisse / Switzerland

GB - ENGLISH

Operating Instructions

Dear Customer,

Many thanks for the confidence you have shown in us with the purchase of your new JET-machine. This manual has been prepared for the owner and operators of a JET JOSS-S oscillating spindle sander to promote safety during installation, operation and maintenance procedures. Please read and understand the information contained in these operating instructions and the accompanying documents. To obtain maximum life and efficiency from your machine, and to use the machine safely, read this manual thoroughly and follow instructions carefully.

Table of contents

Section	Page
1. Declaration of conformity	4
2. JET Group Warranty	4
3. Safety	4
3.1 Authorized use	4
3.2 General safety notes	4
3.3 Remaining hazards	5
3.4 Labels and positions	5
4. Machine specifications	6
4.1 Technical data	6
4.2 Noise emission	6
4.3 Content of delivery	6
5. Setup and assembly.....	6
5.1 Transport and installation	6
5.2 Additional tools required.....	7
5.3 Unpacking and cleanup.....	7
5.4 Removal from pallet	7
5.5 Drum and spindle storage	7
5.6 Installing/removing spindles	7
5.6.1 Small sleeve spindles.....	7
5.6.2 Rubber drums.....	8
5.7 Installing table insert	8
5.8 Wrench storage.....	9
5.9 Dust collection	9
7.0 Adjustments	9
7.1 Rubber shields	9
7.2 Table tilt for bevel sanding	9
7.2.1 Setting 90- and 45-degree stops	10
8.0 Operations.....	10
8.1 Operating guidelines	10
8.2 Working Area	10
8.3 Safety switch	11
8.4 Safety key.....	11
9.0 Maintenance.....	11
9.1 General maintenance	11
9.2 Gearbox lubrication	11
10.0 Troubleshooting JOSS-S Spindle Sander.....	12

1. Declaration of conformity

On our own responsibility we hereby declare that this product complies with the regulations* listed on page 2. Designed in consideration with the standards**.

2. JET Group Warranty

The JET Group makes every effort to assure that its products meet high quality and durability standards and warrants to the original retail consumer/purchaser of our products that each product be free from defects in materials and workmanship as follows:

2 YEAR LIMITED WARRANTY ON ALL PRODUCTS UNLESS SPECIFIED OTHERWISE.

This Warranty does not apply to defects due to directly or indirectly misuse, abuse, negligence or accidents, normal wear-and-tear, repair or alterations outside our facilities, or to a lack of maintenance.

The Jet group limits all implied warranties to the period specified above, from the date the product was purchased at retail.

To take advantage of this warranty, the product or part must be returned for examination, postage prepaid, to an authorized repair station designated by our office.

Proof of purchase date and an explanation of the complaint must accompany the merchandise.

If our inspection discloses a defect, we will either repair or replace the product, or refund the purchase price if we cannot readily and quickly provide a repair or replacement, if you are willing to accept a refund.

We will return repaired product or replacement at JET'S expense, but if it is determined there is no defect, or that the defect resulted from causes not within the scope of JET'S warranty, then the user must bear the cost of storing and returning the product.

The JET Group reserves the right to make alterations to parts, fittings, and accessory equipment which they may deem necessary for any reason whatsoever.

3. Safety

3.1 Authorized use

This spindle sander is designed for sanding wood and similar materials only. Sanding of other materials is not permitted and may be carried out in specific cases only after consulting with the manufacturer.

The machine is not suitable for wet sanding.

The proper use also includes compliance with the operating and maintenance instructions given in this manual.

The machine must be operated only by persons familiar with its operation and maintenance and who are familiar with its hazards.

The required minimum age must be observed.

The machine must only be used in a technically perfect condition.

When working on the machine, all safety mechanisms and covers must be mounted.

In addition to the safety requirements contained in these operating instructions and your country's applicable regulations, you should observe the generally recognized technical rules concerning the operation of woodworking machines.

Any other use exceeds authorization.

In the event of unauthorized use of the machine, the manufacturer renounces all liability and the responsibility is transferred exclusively to the operator.

3.2 General safety notes

Woodworking machines can be dangerous if not used properly. Therefore the appropriate general technical rules as well as the following notes must be observed.

Read and understand the entire instruction manual before attempting assembly or operation.

Keep this operating instruction close by the machine, protected from dirt and humidity, and pass it over to the new owner if you part with the tool.

No changes to the machine may be made.

Daily inspect the function and existence of the safety appliances before you start the machine. Do not attempt operation in this case, protect the machine by unplugging the mains cable.

Remove all loose clothing and confine long hair.

Before operating the machine, remove tie, rings, watches, other jewellery, and roll up sleeves above the elbows.

Wear safety shoes; never wear leisure shoes or sandals.

Always wear the approved working outfit.

Do **not** wear gloves.

Install the machine so that there is sufficient space for safe operation and workpiece handling.

Keep work area well lighted.

The machine is designed to operate in closed rooms and must be placed stable on firm and levelled table surface.

Make sure that the power cord does not impede work and cause people to trip.

Keep the floor around the machine clean and free of scrap material, oil and grease.

Stay alert!

Give your work undivided attention. Use common sense. Do not operate the machine when you are tired.

Do not operate the machine under the influence of drugs, alcohol or any medication. Be aware that medication can change your behaviour.

Never reach into the machine while it is operating or running down.

Never leave a running machine unattended. Before you leave the workplace switch off the machine.

Keep children and visitors a safe distance from the work area.

Do not operate the electric tool near inflammable liquids or gases.

Observe the fire fighting and fire alert options, for example the fire extinguisher operation and place.

Do not use the machine in a damp environment and do not expose it to rain.

Wood dust is explosive and can also represent a risk to health.

Dust from some tropical woods in particular, and from hardwoods like beach and oak, is classified as a carcinogenic substance.

Always use a suitable dust extraction device

Before machining, remove any nails and other foreign bodies from the workpiece.

Never operate with the table insert not in place.

Make sure to guide and hold the workpiece tight during machining.

Machine only stock which rests securely on the table.

Specifications regarding the maximum or minimum size of the workpiece must be observed.

Do not remove chips and workpiece parts until the machine is at a standstill.

Do not stand on the machine.

Connection and repair work on the electrical installation may be carried out by a qualified electrician only.

Have a damaged or worn power cord replaced immediately.

Replace any torn or worn sanding belt immediately.

Make all machine adjustments or maintenance with the machine unplugged from the power source.

3.3 Remaining hazards

When using the machine according to regulations some remaining hazards may still exist.

The moving sanding sleeve can cause injury.

Risk of kickback. The workpiece is caught by the moving sanding sleeve and thrown back to the operator.

Thrown workpiece parts can lead to injury.

Sanding dust and noise can be health hazards. Be sure to wear personal protection gear such as safety goggles and dust mask. Use a suitable dust exhaust system.

Defective sanding discs can cause injuries.

The use of incorrect mains supply or a damaged power cord can lead to injuries caused by electricity.

3.4 Labels and positions

A: Safety warning

B: Spindle rotation direction

C: Spindle lock fully disengaged before running

D: Electrical Shock

E: ID label w/ CE mark

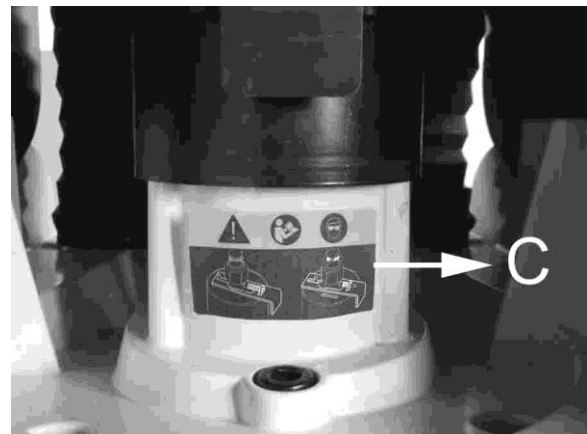
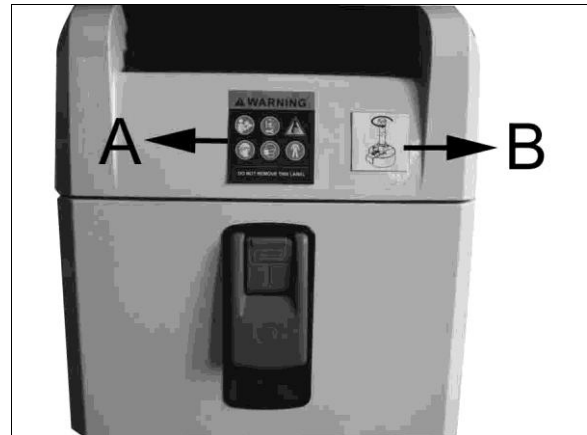

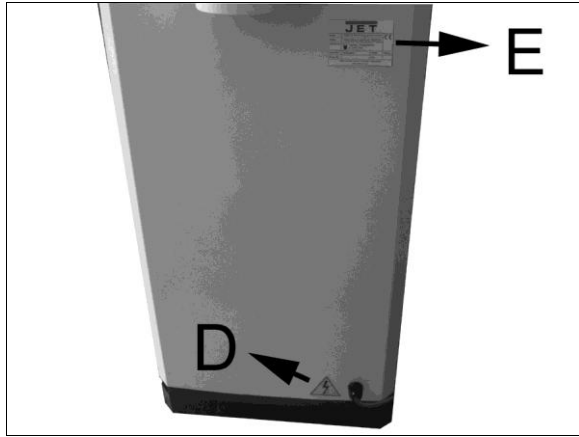

4. Machine specifications

4.1 Technical data

Table size(LxW)	623x623mm
Table tilt	45° front, 15° back
Spindle speed	1400 rpm
Oscillations	60/min
Oscillation stroke	38mm
Sanding sleeve length	150-230mm
Max. workpiece height	80-160mm
Dust port diameter	100mm
suction at 20 m/sec	560m3/h
Overall (LxWxH)	623x623x995mm
Table height	995mm
Net weight	98 kg
Mains	230V ~1/N/PE 50Hz
Output power	0,75 kW (1HP) S1
Reference current	5.5 A
Extension cord (H07RN-F):	3x1,5 ²
Installation breaker protection	10A

4.2 Noise emission

Declared emission value in accordance with EN ISO 4871:

A-weighted sound pressure level (L _{pf})	72.93dB
Uncertainty	3dB
A-weighted sound power level (L _w)	86.07dB

The specified values are emission levels and are not necessarily to be seen as safe operating levels. As workplace conditions vary, this information is intended to allow the user to make a better estimation of the hazards and risks involved only.

4.3 Content of delivery

Most of the below items can be found on or inside sander cabinet. Some items are shipped in the small box which accompanies the machine. One table insert comes installed on the table.

Refer to Figure 1.

- 1 Spindle sander (not shown)
- 6 Table inserts:
 - for 4" (100mm) rubber drum (at 90°) – A
 - for 2" (50mm) rubber drum (at 90°) – B
 - for 3/8" (9mm) spindle (at 90°) – C
 - for 1/4" (6mm) - 3/4" (19mm) spindle (at tilt) – D
 - for 1" (25mm), 1-1/2" (38mm), 2" (50mm) rubber drum (at tilt) – E
 - for 3" (75mm) and 4" (100mm) rubber drum (at tilt) – F
- 1 Rubber drum with sleeve 4" (100mm) – G
- 1 Rubber drum with sleeve 3" (75mm) – H
- 1 Rubber drum with sleeve 2" (50mm) – J
- 1 Rubber drum with sleeve 1-1/2" (38mm) – K
- 1 Rubber drum with sleeve 1" (25mm) – L
- 1 3/4" (19mm) sleeve – M
- 1 3/4" (19mm) Spindle – N
- 1 5/8" (16mm) Spindle with sleeve – O
- 1 1/2" (12mm) Spindle with sleeve – P
- 1 3/8" (9mm) Spindle with sleeve – R
- 1 1/4" (6mm) Spindle with sleeve – S
- 1 Spindle hex nut – T
- 1 Combination wrench (with magnet strip) – U
- 1 Hex wrench 3mm, and magnet strip – V
- 1 Operating manual
- 1 Spare parts list.

Note: All provided sanding sleeves are 100 grit. Additional grits are available – see parts breakdown.

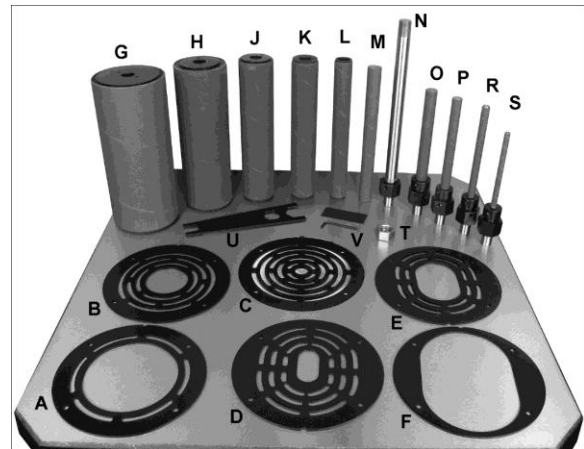

Figure 1

5. Setup and assembly

The sander main unit requires no assembly. Set-up involves only removing sander from pallet, and installing desired table insert and spindle/sleeve combination.

5.1 Transport and installation

The machine is designed to operate in closed rooms and must be placed stable on a firm and levelled surface.

5.2 Additional tools required

Ratchet wrench with socket set (or adjustable wrench)
Cross-point (Phillips) screwdriver
Machinist square
Straight edge

5.3 Unpacking and cleanup

Inspect all contents from shipping carton, including parts inside cabinet (accessed through the side door). Report any damage or part shortages to your distributor.

Exposed metal surfaces, such as table surface, have been given a protective coating at the factory. This coating should be removed with a soft cloth moistened with solvent, such as mineral spirits. Do not use solvents with low flash points, or allow solvents near plastic or rubber parts. Do not use an abrasive pad as it may scratch exposed surfaces.

Periodically apply a light coat of paste wax or other protectant to the table top to prevent rusting.

5.4 Removal from pallet

To remove sander from pallet:

1. Open cabinet door and remove accessories.
2. Use ratchet wrench with extended socket to unscrew two bolts securing machine to pallet (Figure 2).
3. Move sander off pallet, with help from an assistant.

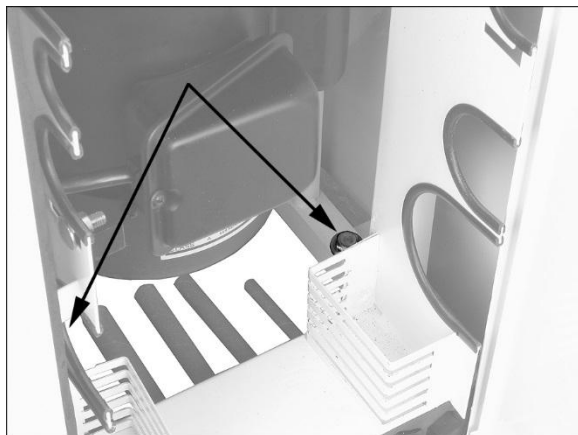

Figure 2

5.5 Drum and spindle storage

Keep drums, spindles and table inserts protected by storing them in cabinet (Figure 3). To open door, lift bottom of latch and rotate counterclockwise 90 degrees (Figure 4). Reverse procedure to close cabinet door.



Figure 3: cabinet storage

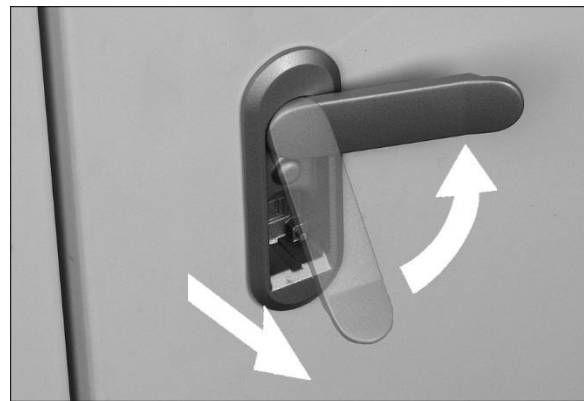

Figure 4: door latch

5.6 Installing/removing spindles

⚠WARNING Disconnect sander from power source when installing or removing sanding assemblies. Failure to comply may cause serious injury.

Open front shield (see sect. 8.1 Rubber Shields).

Thoroughly clean tapered area (A, Figure 5) on all spindle assemblies before installing. Also clean mating shaft on sander.

Remove table insert if installed.

Table may be tilted 15° backward to improve access (see sect. 8.2.)

5.6.1 Small sleeve spindles

Refer to Figure 5.

1. Slide sanding sleeve (B) completely onto spindle, ensuring that it slides into collar (C).

2. Tighten set screw on collar (C) with provided 3mm hex wrench. Do not overtighten.
3. Pull on sleeve to ensure it is secure.
4. Position spindle taper (A) into main shaft and hold.
5. Rotate nut (D) clockwise by hand, as viewed from above. Continue rotating nut until spindle seats (stops turning with nut), then continue rotating nut until it is hand-tight.
6. Push in and hold spindle lock (E). Note: Rotate spindle to ensure proper engagement.
7. Use provided combination wrench to tighten nut further. Do not overtighten.
8. Release spindle lock. Make sure it retracts by rotating spindle slightly.

CAUTION Make sure spindle lock has fully disengaged before turning on sander, or damage to motor may result.

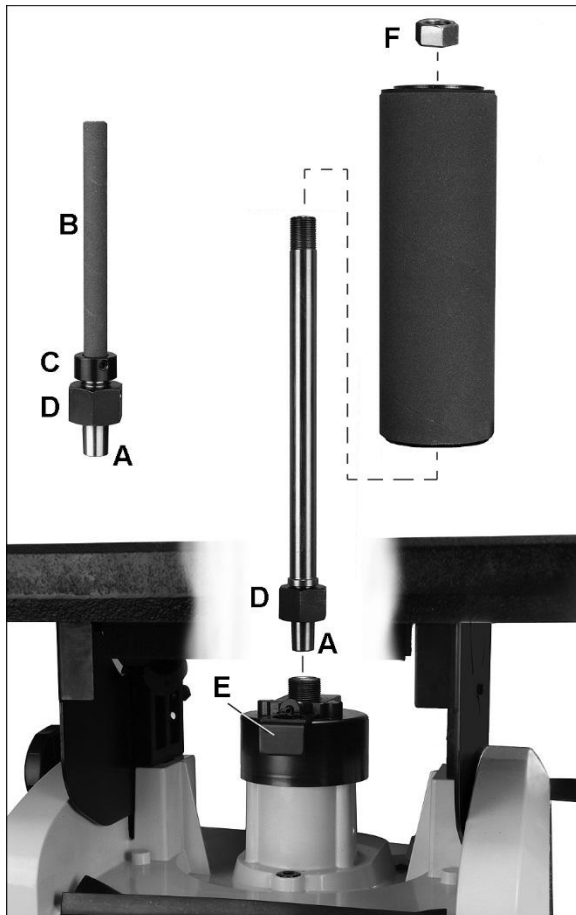

Figure 5: Spindle and drum mounting

5.6.2 Rubber drums

Refer to Figure 5.

1. Position spindle taper (A) into main shaft and hold.
2. Rotate nut (D) clockwise by hand, as viewed from above. Rotate nut until spindle seats (stops turning with nut), then continue rotating nut until it tightens.

3. Push and hold spindle lock (E). Note: Rotate spindle to ensure proper engagement.
4. Use provided combination wrench to tighten nut further. Do not overtighten.
5. Slide sanding sleeve completely onto drum until its bottom edge is even with drum.
6. Slide drum/sleeve assembly down fully onto spindle.
7. Push and hold spindle lock (E).
8. Install hex nut (F) onto spindle threads and tighten clockwise (as viewed from above) with provided combination wrench.
9. Pull on sleeve to ensure it is secure. If it slides, tighten nut (F) a bit further. Do not overtighten.
10. Release spindle lock (E). Make sure it retracts by rotating spindle slightly.

CAUTION Make sure spindle lock has fully disengaged from spindle before turning on sander, or damage to motor may result.

To remove a spindle, reverse the above procedure(s).

5.7 Installing table insert

Tools required:

- cross-point screwdriver
- straight edge

CAUTION Failure to use proper table insert with corresponding spindle/drum may result in personal injury and/or damage to workpiece.

Table inserts are round or oblong. Table 1 identifies purpose of each.







Insert	Used with spindle (diameter)	Table angle
	3" and 4" drum	0 deg.
	1/2, 5/8, 3/4, 1, 1-1/2, 2" drum	0 deg.
	1/4" TO 3/8"	0 deg.
	1/4, 3/8, 1/2, 5/8 and 3/4"	Up to 45 deg.
	1, 1-1/2, 2" drum	Up to 45 deg.
	3" and 4" drum	Up to 45 deg.

Table 1: Table insert identification

1. Position insert into table, so that notch is captured by the pin (A, Figure 6).
2. Place straight edge over insert and table. If gaps appear between straight edge and insert, turn screw(s) to raise or lower insert. Reposition straight edge at right angle to check level in both directions.

Note: Leveling one insert is sufficient as all inserts are same thickness.

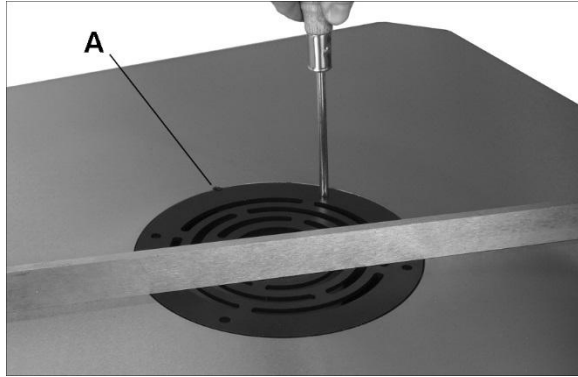

Figure 6: mounting table insert

5.8 Wrench storage

The provided combination wrench has a magnetic strip, and can be placed against any metal surface.

Expose the adhesive on the additional magnetic strip and apply anywhere on the cabinet surface. The hex key can be stored against it.

5.9 Dust collection

A sander produces a significant volume of wood dust; the use of a dust collection system is strongly recommended. It will help keep the shop clean, as well as reduce potential health hazards caused by inhalation of wood dust. The collector should have a capacity sufficient for this size machine; minimum 20m/sec flow rate is recommended.

JET has a line of dust collection systems available; see your dealer or visit our website listed on the cover.

Connect the hose of your dust collection system to the 100mm dust port (Figure 7) at rear of sander. Secure tightly with a hose clamp.

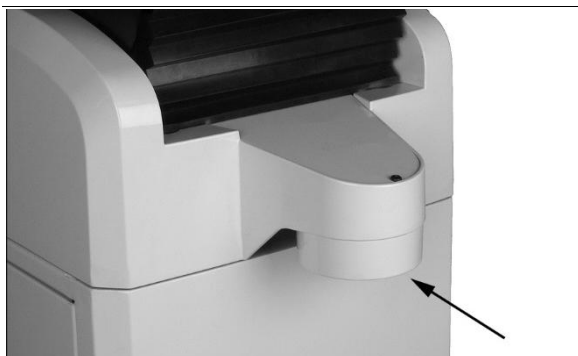

Figure 7

6.0 Mains connection

Mains connection and any extension cords used must comply with applicable regulations. The mains voltage must comply with the information on the machine licence plate.

The mains connection must have a 10 A surge-proof fuse.

Only use power cords marked H07RN-F

Connections and repairs to the electrical equipment may only be carried out by qualified electricians.

7.0 Adjustments

⚠WARNING Disconnect sander from power source before making adjustments.

7.1 Rubber shields

Refer to Figures 9 and 10.

Front and rear rubber shields are connected at top by hook-and-loop fasteners. Peel off top of shield to access spindle area (Figure 9).

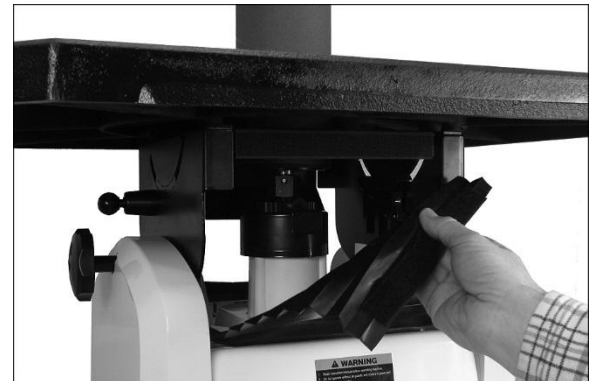

Figure 9: front shield

IMPORTANT: Before tilting table to maximum degree forward, move top of shield from upper position (A) to lower position (B).

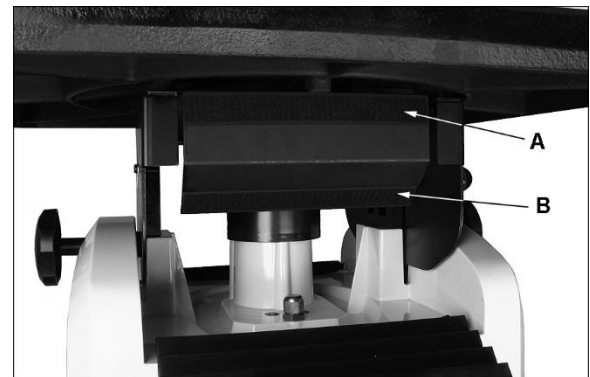

Figure 10: rear shield

7.2 Table tilt for bevel sanding

Refer to Figures 11 and 12.

1. Loosen both knobs (A, Figure 11) counterclockwise.

To tilt forward (45-degree maximum):

2. Move table by hand to desired angle shown on scale (B). Scale is marked in 5-degree increments.
3. Retighten knobs (A).

To tilt backward (15-degree maximum):

4. Pull out pin (C) and rotate it 90-degrees to keep it disengaged.
5. Tilt table to desired position, and tighten knobs (A).

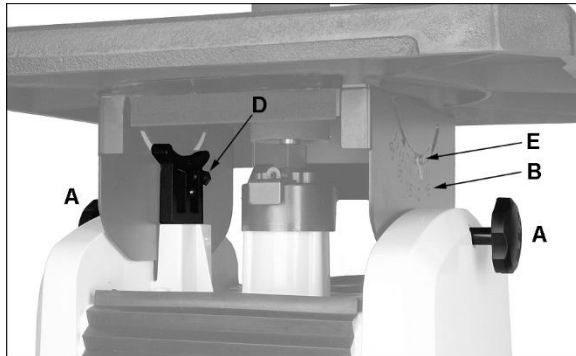

Figure 11: table tilt

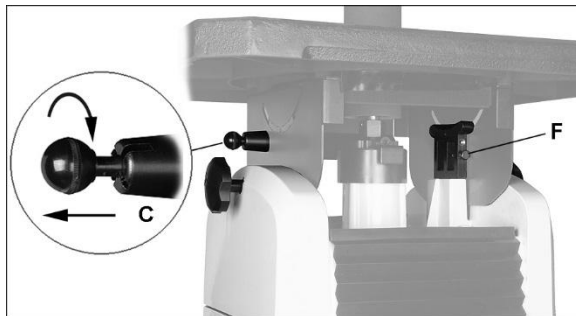

Figure 12: table tilt

7.2.1 Setting 90- and 45-degree stops

Tools required:
 machinist square
 13mm wrench

Refer to Figures 11 through 13.

1. Make sure table insert has been leveled with table (sect. 6.7).
2. Make sure pin (C) is re-engaged to contact stop screw. Position table at zero (90-degrees) against stop screw (D).
3. Place square on table and against front of drum or spindle (Figure 13).
4. Rotate screw (D) until square sits flush against table and spindle/drum.
5. If needed, loosen pointer (E) and align it with zero degree mark.
6. Tilt table to 45-degrees and check accuracy of 45-degree stop screw (F). Adjust as needed.

Note: The above procedure is sufficient for most wood sanding operations. If greater angle precision is needed, remove insert and use a larger square flush against a bare spindle and table surface to set 90-degree stop.



Figure 13: setting tilt stop

8.0 Operations

8.1 Operating guidelines

1. Select spindle that is slightly smaller than curve to be sanded.
2. Make sure spindle is properly secured on main shaft.
3. Use table insert that has smallest opening possible without contacting sanding sleeve.
4. Loosen both table handles and position table at desired angle. Tighten both table handles before operating.
5. Turn on sander and allow it to reach full speed before starting work.
6. Hold workpiece firmly and against table at all times.
7. For best results, keep workpiece moving against spindle.
8. When table is at zero (90-degrees), workpiece may approach sanding sleeve from any part of table. When table is tilted, use table area in front of spindle.
9. Sanding sleeve life may be prolonged by reversing it on the spindle to make use of opposite end.

8.2 Working Area

Make sure the working area is sufficient and proper for operation. The recommended minimum area is shown as below figure.

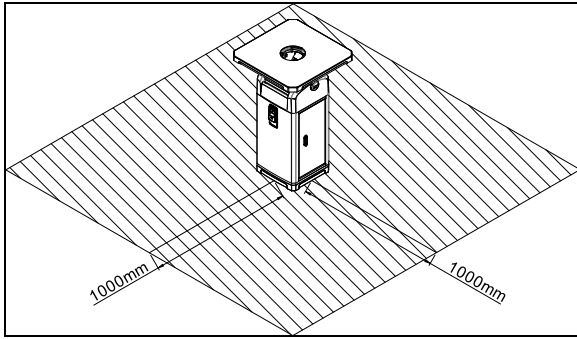

CAUTION Keep fingers clear of sanding sleeve and table insert hole during operation.

8.3 Safety switch

Refer to Figure 14.

To start sander, push green button (A).

To stop sander, push red button (B).

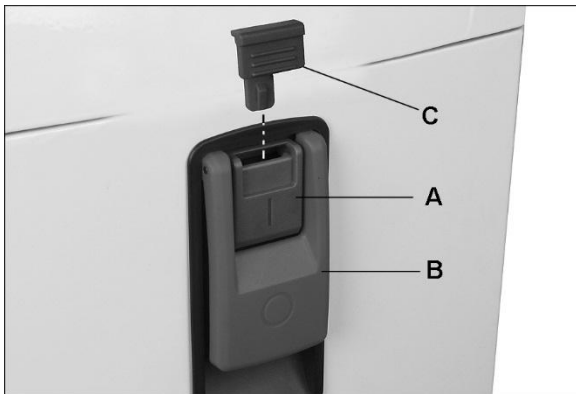

Figure 14

WARNING If power to the sander is interrupted, the machine will restart immediately once power is restored, unless the red stop button has been pushed.

8.4 Safety key

The switch has a safety feature that prevents unauthorized or accidental starting of the sander.

With sander turned off, slide safety key (C, Figure 14) upward and remove it from switch. Store in a safe place. This piece must be re-inserted before sander can operate.

9.0 Maintenance

WARNING Always disconnect power to the machine before performing maintenance. Failure to do this may result in serious personal injury.

9.1 General maintenance

Clean the sander after each use. Vacuum any residual dust inside the cabinet and around spindle area.

Periodically apply a light coat of paste wax or other protectant to the table surface to prevent rust.

All bearings are permanently lubricated and sealed; no further lubrication required.

9.2 Gearbox lubrication

Periodically check oil level at the sight glass (D, Figure 15) – oil should be mid-level in the glass.

Use good quality SAE 90 gear oil.

Completely drain and refill after every 800 hours of use. Oil capacity is 1.6 liters.

To drain and refill gearbox:

1. Remove accessories from inside cabinet to access drain plug.
2. Remove drain plug (E, Figure 15) with 14mm wrench. Dispose of used oil properly. Reinstall drain plug.
3. Open rear shield, and clean area around oil cap. Unscrew oil cap (F, Figure 16) by hand, and remove spring.
4. Fill reservoir until oil level is at center of sight glass.
5. Reinstall spring and oil cap.



Figure 15

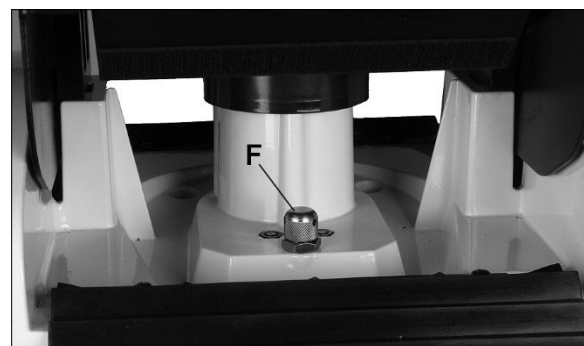

Figure 16

10.0 Troubleshooting JOSS-S Spindle Sander

Symptom	Possible Cause	Correction
Sander will not start.	Sander unplugged from wall or motor.	Check all plug connections.
	Fuse blown, or circuit breaker tripped in service panel.	Replace fuse, or reset circuit breaker.
	Cord damaged.	Replace cord.
	Starting capacitor bad.	Replace starting capacitor.
Sanding drum does not come up to speed.	Extension cord too light or too long.	Replace with adequate size and length cord.
	Low current.	Contact a qualified electrician.
Machine vibrates excessively.	Stand or base on uneven surface.	Adjust stand or base so that it rests evenly on the floor.
	Bearings worn.	Replace bearings.
Sanded edge not square.	Table not square to sanding drum.	Use a square to adjust table to sanding drum.
Sanding marks on wood.	Wrong grit sanding sleeve.	Use coarser grit for stock removal and fine grit for finish sanding.
	Feed pressure too great.	Do not force workpiece against spindle or drum.

Table 3

11.0 Available accessories

Refer to the JET-Pricelist for various grit sanding sleeves.